

Tele-Existence Master Slave System for Remote Manipulation (II)

Susumu Tachi, Hirohiko Arai, and Taro Maeda

MECHANICAL ENGINEERING LABORATORY, MITI
TSUKUBA SCIENCE CITY, IBARAKI 305 JAPAN

Abstract

A tele-existence master slave system for remote manipulation experiments is designed and developed, and an evaluation experiment of a tele-existence master slave system is conducted. By making a comparison of a tele-existence master slave system with a conventional master slave system, efficacy of the tele-existence master slave system is verified and the superiority of the tele-existence method is demonstrated through several experimental tasks.

1. Introduction

Remote operation plays an important role in hostile environment such as those of nuclear, high temperature, and deep space. In spite of the efforts of many researchers, a teleoperation system that is comparable to the human's direct operation has not been developed. The authors have been working on the research for the improvement of the teleoperation by feeding back rich sensory information which the remote robot has acquired to the operator with a sensation of presence, the concept which is called tele-existence [1-6] or telepresence [7-9].

Tele-existence aims at a natural and efficient remote control of robots by providing the operator with a real time sensation of presence. It is an advanced type of teleoperation system which enables a human operator at the controls to perform remote manipulation tasks dexterously with the feeling that he or she

exists in one of the remote anthropomorphic robots in the remote environment, e.g., in a hostile environment such as those of nuclear radiation, high temperature, and deep space.

In the previous reports [1,2], the principle of the tele-existence sensory display was proposed. Its design procedure was explicitly defined. Experimental visual display hardware was built, and the feasibility of the visual display with the sensation of presence was demonstrated by psychophysical experiments using the test hardware. A method was also proposed to develop a mobile tele-existence system, which can be remotely driven with the auditory and visual sensation of presence. A prototype mobile televehicle system was constructed and the feasibility of the method was evaluated [2]. The principle of active power assistance was applied for controlling the visual display with two degrees of freedom [3,4]. In order to study the use of the tele-existence system in the artificially constructed environment, the visual tele-existence simulator was designed, a quasi-real-time binocular solid model robot simulator was made, and its feasibility was experimentally evaluated [5].

In the recent paper [6], the first prototype tele-existence master slave system for remote manipulation experiments was designed and developed, and a preliminary evaluation experiment of tele-existence was conducted.

In this paper, the tele-existence system has been redesigned and redeveloped for conducting experimental manipulation tasks, and by conducting an experiment comparing a tele-

existence master slave system with a conventional master slave system, efficacy of the tele-existence master slave system and the superiority of the tele-existence method is demonstrated experimentally.

2. Tele-Existence Master Slave System

Figure 1 shows the schematic diagram of the tele-existence master slave manipulation system. The tele-existence master slave system consists of a master system with a visual and auditory sensation of presence, computer control system and an anthropomorphic slave robot mechanism with an arm having seven degrees of freedom and a locomotion mechanism. The operator's head movement, right arm movement, right hand movement and other auxiliary motion including feet motion are measured by the master motion measurement system in real time without constraint. The measured head motion signal,

arm motion signal, hand motion signal, and auxiliary signal are sent to the four computers, respectively. Each computer generates the command position of the slave head movement, the arm movement, hand movement or locomotion of the slave robot. The servo controller controls the movement of the slave anthropomorphic robot. A six axis force sensor installed at the wrist joint of the slave robot measures the force and torque exerted upon contact with an object. The measured signal is fed back to the computer in charge of the arm control through A to D converters. Force exerted at the hand when grasping an object is also measured by a force sensor installed on the link mechanism of the hand. The measured signal is also fed back to the computer in charge of the hand control through another A to D converter.

A specially designed stereo visual and auditory input system mounted on the neck mechanism of the slave robot gathers visual and auditory

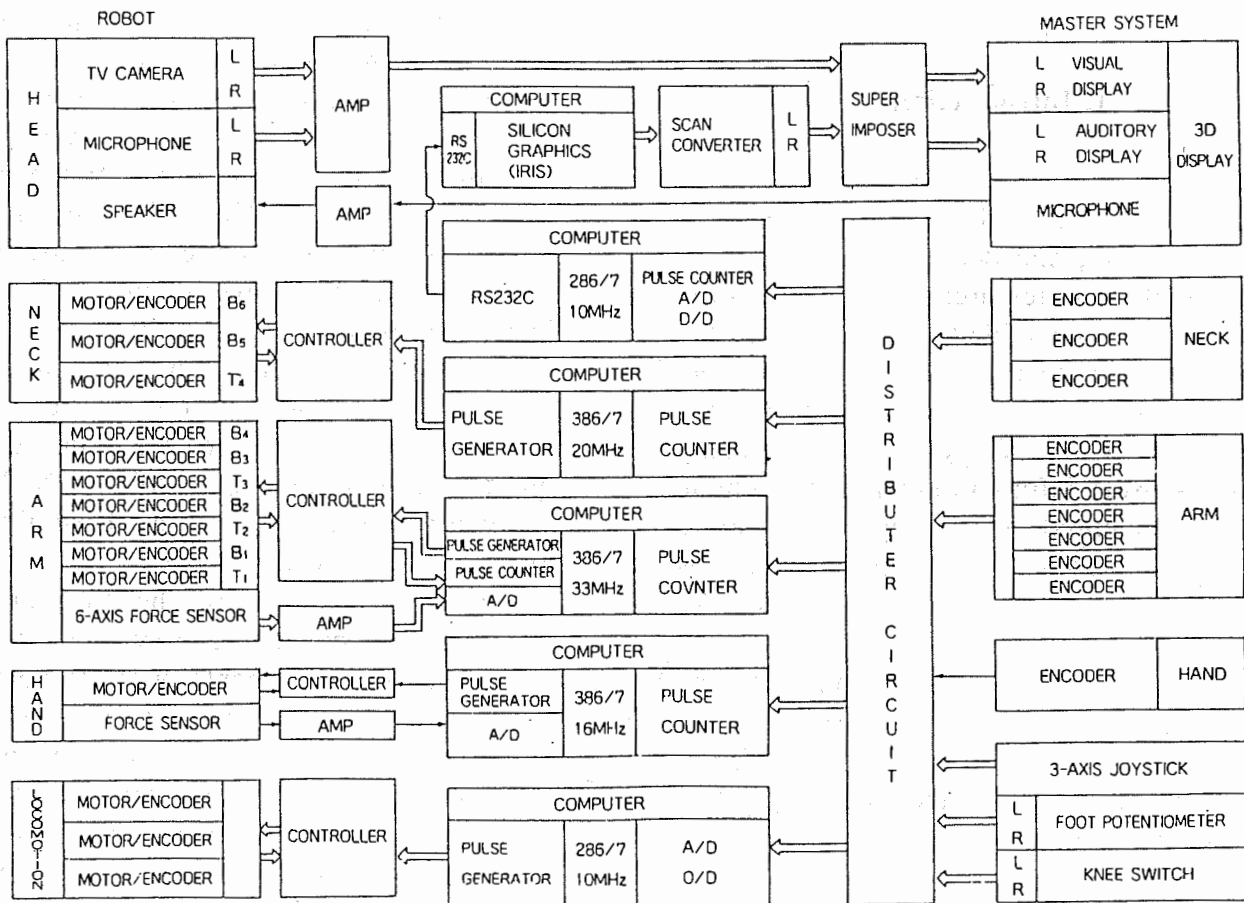

Fig.1 Block Diagram of the Tele-Existence Master Slave Manipulation System.

information of the remote environment. These pieces of information are sent back to the master system, which are applied to the specially designed stereo display system to evoke sensation of presence of the operator.

Measured human movements (head, arm, hand, and auxiliary) are also applied to another computer which is in charge of the generation of computer graphics (Silicon Graphics IRIS 120GTX) through a dedicated computer for measurement. The graphics computer generates two shaded graphic images which are applied to the 3D visual display through superimposers. The measured pieces of information on the human movement are used to change the viewing angle, distance to the object, and condition between the object and the hand in real time (10–20 Hz). the operator sees the three dimensional virtual environment in front of his view, which changes according to his movement. He or she can interact with either the real environment which the robot observes, or the virtual environment which the computer generates. The virtual environment can be superimposed on the real environment.

Figure 2 shows a general view of the tele-existence master slave system designed and developed.

The slave robot is fundamentally the same as

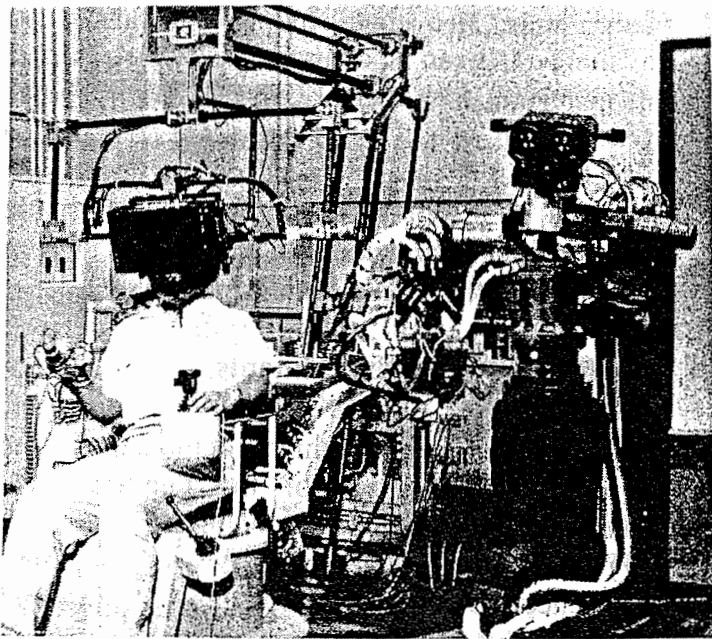

Fig.2 General view of the master system (left) and anthropomorphic slave robot (right).

that reported in the previous report [6] except the addition of a locomotion mechanism and the redesign of a hand mechanism. The robot has a three degree of freedom neck mechanism on which a stereo camera is mounted. It has an arm with seven degrees of freedom, and a torso mechanism with one degree of freedom (waist twist). The robot's structural dimensions are set very close to those of a human [4]. The weight of the robot is 60 kg, and the arm can carry a 1 kg load at the maximum speed of 3 m/s. The precision of position control of the wrist is ± 1 mm. The dimensions and arrangement of the degree of freedom of the robot are designed to mimic those of the human being. The motion range of each degree of freedom is set so that it will cover the movements of a human, while the speed is set to match the moderate speed of human motion (3 m/s at the wrist position).

A combination of a D.C.servo motor and a harmonic drive reduction mechanism is used as an actuator for each joint except the elbow extension/flexion, which includes conventional gears. The location of the motors is designed so that the appearance of the arm resembles a human arm as closely as possible, and the range and the speed of the manipulator satisfy the necessary specifications.

The impedance control is used in this experiment. The computer generates a pulse sequence to assign the desired position based on the calculation of the desired impedance assigned at the hand and measured force, and the impedance based position control is conducted by counting the difference between the computer generated pulse and the measured pulse from an encoder.

A schematic figure of the locomotion mechanism designed is shown in Fig. 3. It is a planar motion mechanism whose position is assigned by polar coordinate (r, θ) , where $r = 500 \sim 1500$ [mm] and $\theta = 0 \sim 270$ [deg]. The orientation of the robot is assigned by the waist rotation angle of the robot ϕ , where $\phi = -150 \sim 150$ [deg].

A hand mechanism of one degree of freedom, which can either pinch or grasp, has been newly

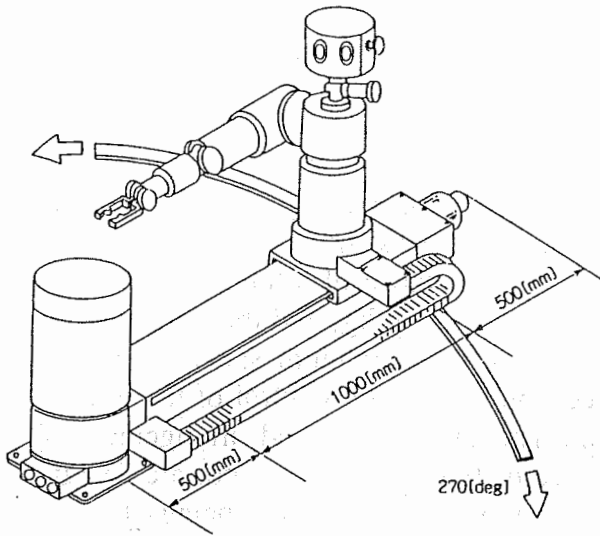

Fig.3 Schematic diagram of the locomotion system.

designed. It is designed to be able to pinch small objects (from diameter of 2 mm) and rather big object (up to diameter of 114 mm). It uses a parallel link mechanism and ball screw as shown in Fig. 4. The grasping of cylindrical objects with a minimum diameter of 15 mm can be done with contact at three points as is shown in the figure. This makes the grasping stable. Strain gauges are placed on two finger links, respectively, which measure the grasping force. The average grasping force is 5 Kgf. Measurement of the opening is done by an encoder attached to the DC motor. Position control with an average resolution of 0.01 mm is attained. A six-axis force sensor is installed at the wrist position. The hand is made of durable aluminum and weighs 620 g including the force sensor.

The vision system of the slave robot consists of two color CCD video heads from TV cameras. Each CCD has 420,000 pixcells and has its optical system with a focal length of $f=12$ mm (field of view 40 [deg]) and an aperture of F 1.6. Focus is automatically controlled by the TTLAF method. The separation of two cameras are set at the distance of 65 mm, and the two cameras are aligned parallel to each other.

As for the auditory system, two microphones are placed 243 mm apart from each other, and the same locational relation is used for the auditory display of the master system. A small

speaker is placed at the location of the mouth, which transmit the operator's voice.

The master system is fundamentally the same as the one reported in [6] except for a newly designed and developed stereo audio visual display. A human operator wears the 3D display with a sensation of presence. The audio visual display is carried by a link mechanism with six degrees of freedom. The link mechanism cancels all gravitational force through a counter balancing mechanism with a relatively wide range of operation. It also enables the display to follow the operator's head movement precisely enough to ensure his/her ordinary head movement. Maximum measured inertial force is within 5 kgf. The master arm consists of ten degrees of freedom. Seven degrees of freedom are allocated for the arm itself, and an additional three are used to comply with the body movement.

Stereo visual display is redesigned according to the developed procedure which assures that the three dimensional view will maintain the same spatial relation as by direct observation [1,2]. Adding to the fundamental design procedure, an optical system using polarizers and analyzers was introduced to eliminate the unnecessary reflected image caused by the internal mirror[6]. In the new model a helmet is used to fit on the head. Three sizes are available and can be changed easily by a buckle mechanism. Six inch LCDs (H720 x V240 pixcells) are used. Two mirrors are arranged so that the LCDs can be placed on the upper side in front of the operator. These made possible the compact arrangement of the display system suitable for the manipulation master system.

3. Experiments

Three experiments which demonstrate the typical characteristics of the tele-existence master slave system were conducted.

(1)The most important features of the tele-existence include the natural three dimensional vision (close to direct observation), which follows an operator's head movement in real time. Another feature is the natural

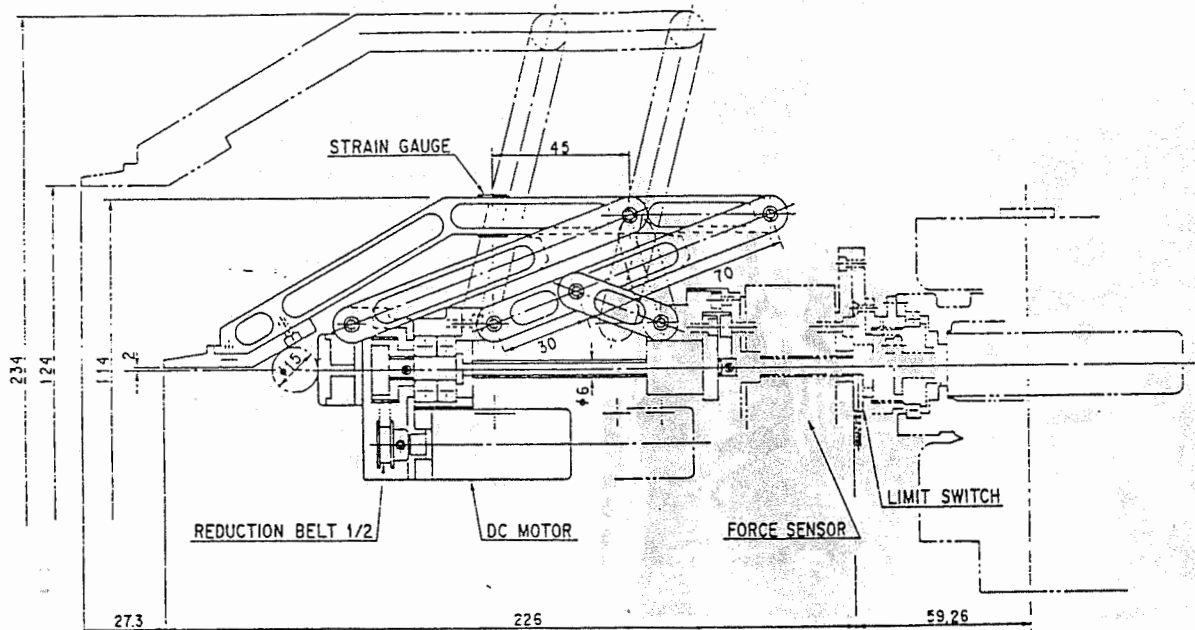

Fig.4 Slave hand mechanism (This figure shows half of the symmetric mechanism).

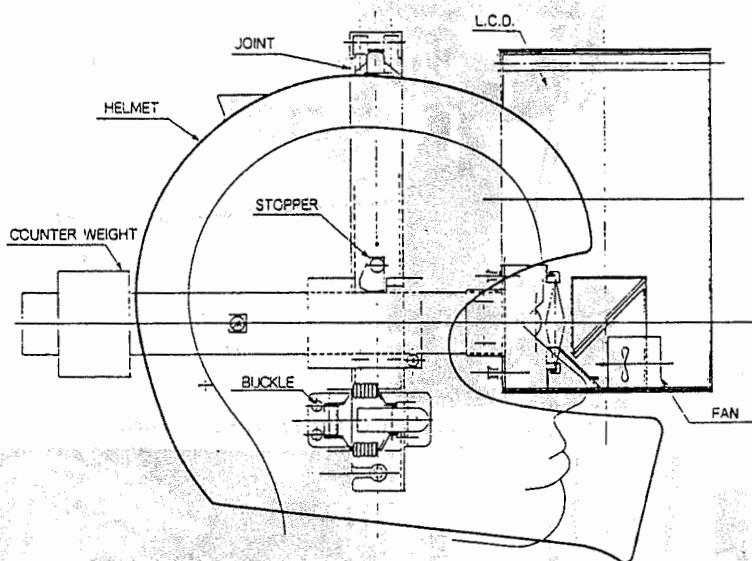

Fig.5 Head-linked stereo display.

correspondence of visual information and kinesthetic information, i.e., an operator observes the slave's anthropomorphic arm at the position where his/her arm is supposed to be.

This allows the operator at the control to perform tasks which need coordination of hand and eye quickly as in the case of direct operation.

Figure 6 shows a general view of an experimental manipulation task of building blocks randomly placed on a table against a

natural background under natural lighting condition. Block building is usually done within few seconds without training, whereas conventional teleoperation using the same master, the slave and a conventional two dimensional TV as a monitor takes training. A trained operator takes several minutes to attain the same task.

(2)The combination of fundamental tele-existence technology with other advanced technology such as virtual environment display and impedance control makes it possible to use robots in hazardous environments. Figure 7 shows that the robot works on the supposition that a pipe of a chemical plant is leaking and the plant is filled with toxic gas. The operator analyzes the situation using a virtual model environment of the plant generated by the computer according to the blueprint of the plant while the robot goes to the plant. The model environment is displayed by using the same display which is used for the tele-existence operation.

When the robot arrives at the plant, the operator observes the situation through the robot's sensors as if he/she were at the spot.

The operator conducts the emergency action by closing the valve and pushing the switch of the exhaust fan. The model environment can be superimposed on the real scenery.

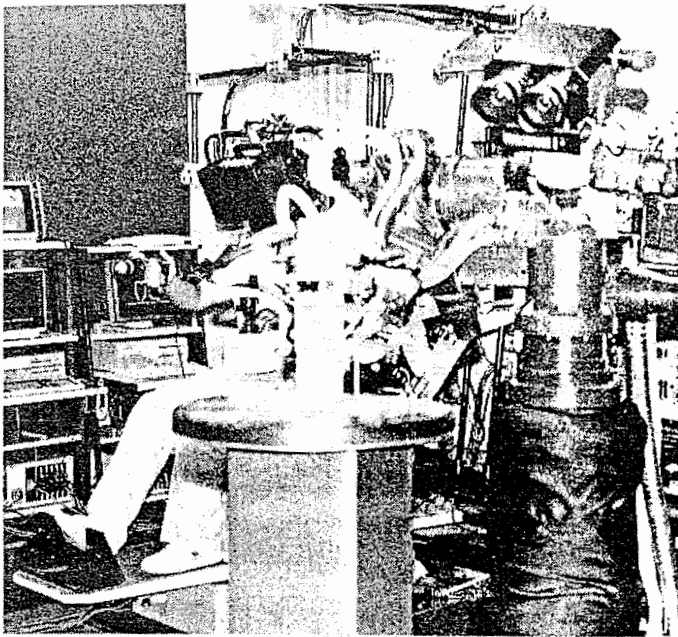

Fig.6 Experiment of handling blocks.

Impedance control of the slave robot's manipulator helps conduct quick manipulation tasks like closing valves and pushing switches. (3)By using tele-existence, natural human robot communication becomes possible. In other words, robots can be used in such situations that human robot collaboration is necessary. Figure 8 shows an example of human robot communication. The robot presents a bunch of flower to a lady on behalf of a person at the control.

By conducting these experiments, efficacy of the tele-existence master slave system was verified and the superiority of the tele-existence method was experimentally demonstrated.

References

- [1]S.Tachi et al., "Tele-existence (I) -Design and evaluation of a visual display with sensation of presence-", Proceedings of the 5th Symposium on Theory and Practice of Robots and Manipulators (RoManSy 84), pp.245-254, CISM-IFTOMM, Udine, Italy, June 1984.
- [2]S.Tachi, H.Arai, I.Morimoto and G.Seet, "Feasibility experiments on a mobile tele-existence system," The International Symposium and Exposition on Robots (19th ISIR), Sydney, Australia, November 1988.
- [3]H.Arai, S.Tachi and I.Miyazima, Development of a power-assisted head-coupled display system using a direct-drive motor," *Advanced Robotics*, vol.3, no.2, pp.123-130, 1989.
- [4]S.Tachi, H.Arai and T.Maeda, "Development of an Anthropomorphic tele-existence slave robot," Proceedings of the International Conference on Advanced Mechatronics (ICAM), pp.385-390, Tokyo, Japan, May 1989.

- [5]S.Tachi, H.Arai and T.Maeda, "Tele-existence simulator with artificial reality (1), -Design and evaluation of a binocular visual display using solid models -," Proceedings of the IEEE International Workshop on Intelligent Robots and Systems (IROS'88), pp.719-724, 1988.

- [6]S.Tachi, H.Arai and T.Maeda, "Tele-Existence Master Slave System for Remote Manipulation," IEEE International Workshop on Intelligent Robots and Systems (IROS'90), pp.343-348, 1990.

- [7]J.D.Hightower, E.H.Spain et al., "Telepresence: A hybrid approach to high-performance robots," Proceedings of the '87 International Conference on Advanced Robotics (ICAR), pp.563-573, Versailles, France, October 1987.

- [8]L.Stark et al., "Telerobotics: Display, Control, and Communication Problems," IEEE Journal of Robotics and Automation, vol.RA-3,no.1,pp.67-75, 1987.

- [9]S.S.Fisher et al., "Virtual environment display system," ACM 1986 Workshop on Interactive 3D Graphics, pp.1-11, Chapel Hill, North Carolina, October 1986.

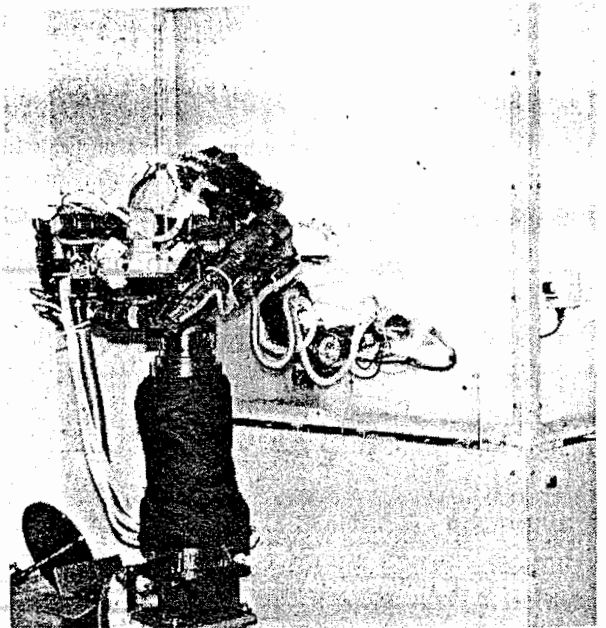

Fig.7 Experiment in hazardous environment.

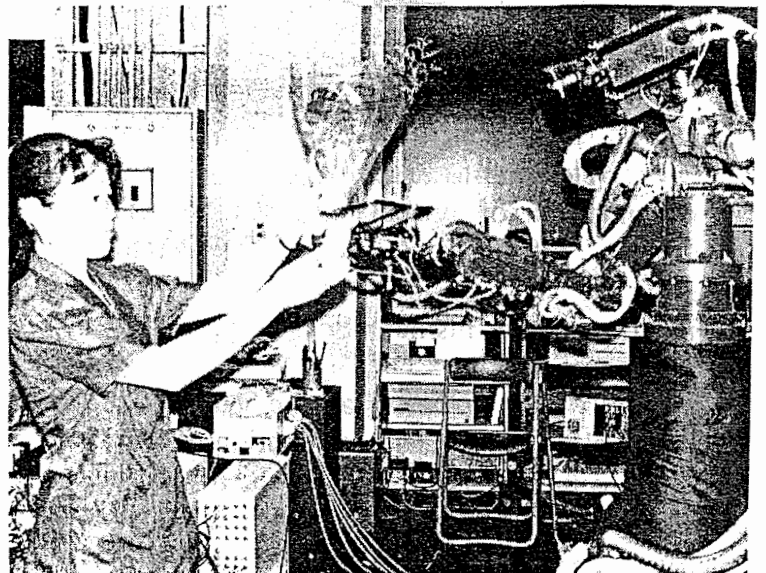

Fig. 8 Human robot communication.